

1/2" THERMOSTATIC SET W/ CONTOUR HANDLE

ITEM 00.02.05

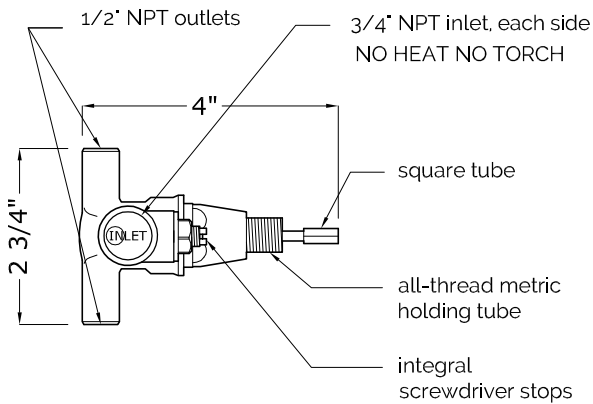
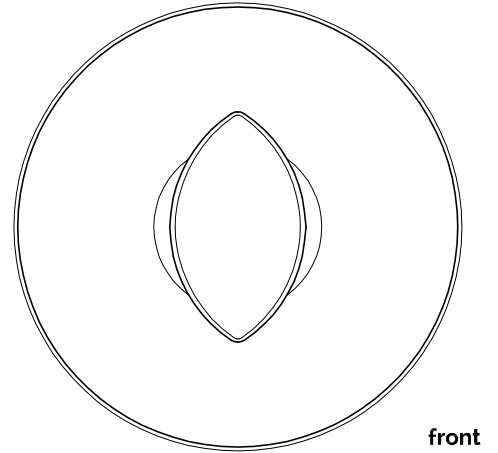
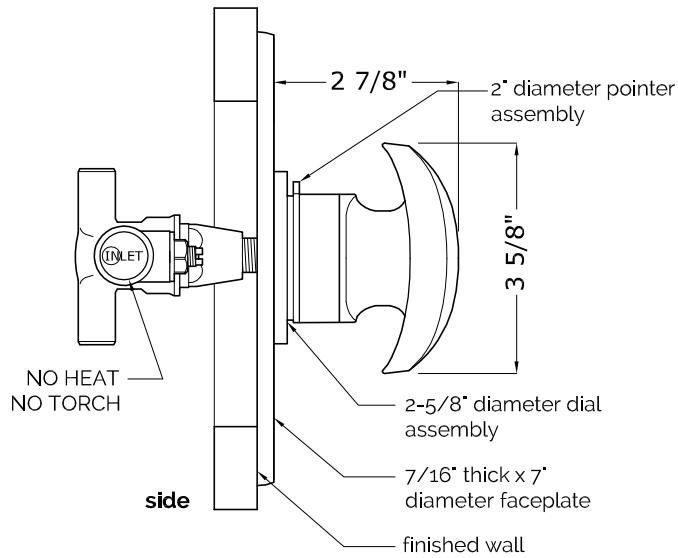

1/2" THERMOSTATIC VALVE
- 14.5 GPM @ 45 PSI (9.5 GPM top exit)

COMPONENTS

- 1/2" valve included, 3/4" valve also available
- separate shut off valve required to operate system

NOTE

- see installation instructions for proper depth of valve to the finished wall

CODES

- certified to meet or exceed: ASME A112.18.1 and CSA B12